

Applications:
Wireless Control
Garage Door Opener
Remote Data Acquisition
Car Alarm/Keyless Entry

RE RECEIVER BOARD



The RE-99 V3.0A is a LC-based 300MHz AM RF super-regenerative receiver board. It is ideal for almost any application needing a wireless control system. When used with the TX-99K key-chain transmitter and the RE-01 decoder motherboard, the RE-99 is perfect for use as a keyless entry system for your home or automobile. If your application requires the ability to send data codes, the TX-99 transmitter and TX-01 encoder motherboard, combined with the RE-99 receiver and RE-01 decoder motherboard, will allow 4-bit data transmission. This set works well in applications such as gathering data from remote sensors or controlling remotely located objects such as lights, valves, motors or just about anything else.

Specifications

ELECTRICAL	
Operating Voltage:	5VDC
Operating Current:	1.6mA
Frequency:	300 MHz
Circuit Type:	LC Based AM
ENVIRONMENTAL	
Operating Temp:	0°C to 40°C
Storage Temp:	-20° to 80°C
PHYSICAL	
Length:	1-3/16" (30.16mm)
Width:	2-3/8" (60.33mm)
Height:	11/16" (17.46mm)
Weight:	1.6oz (.056gms)

Other Available RF Products

Transmitter/Receiver Sets:

TX-99K1- 300MHz AM RF LC-based single-button transmitter with encoder
TX-99K2- 300MHz AM RF LC-based Two-button transmitter with encoder
TX-99 V3.0- 300MHz AM RF LC-based transmitter
RE-99 V3.0A- 300MHz AM RF super regenerative receiver
TX-66 V3.0- 310MHz AM RF transmitter with SAW resonator
RE-66 V3.0A- 310MHz AM RF super-regenerative receiver

Encoder/Decoder Sets:

TX-01- 12-bit encoder motherboard (8-bit address/4-bit data)
RE-01- 12-bit decoder motherboard (8-bit address/4-bit data)

Antenna Information

The RE-99 requires a wire antenna for optimum operating distance. A wire antenna is a piece of insulated or non-insulated wire cut to a specific length and soldered to the antenna connection point of the receiver board.

We recommend using 22 gauge wire cut to 9.36" (1/4 wave). Most people use the 1/4 wave antenna because it is fairly short and works very well, but if desired, a half or full wave antenna may be used. Better results can be achieved using a half or full wave antenna, but a lengthy antenna is sometimes hard to conceal.

If coax cable is required for your application, please see the diagram below.

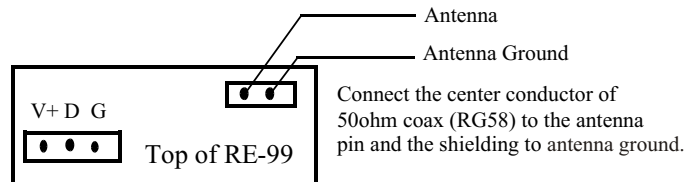

Testing and Troubleshooting

Certain problems can arise when working with RF products. If the transmitter or receiver boards are not accurately tuned, or possibly defective, the desired signal may never reach its destination. At the same time, if the address of the encoder board does not match the address of the decoder board, or either board is defective, again, the desired signal may never reach its destination. It is sometimes very difficult to tell what the actual problem is. The following instructions should be helpful.

The first thing to be tested are the encoder motherboard (TX-01) and decoder motherboard (RE-01). These will become very useful in testing, and if necessary, tuning the transmitter and receiver. To check the TX-01 and RE-01 you must remove the transmitter and receiver from these boards. Make sure both motherboards are connected to the same power supply. Connect the data-pin on the TX-01 to the data-pin on the RE-01 (located on the 3pin connector) with a piece of wire. With both addresses matched and power applied, the Valid ID relay on the RE-01 should be closed. If the relay is not closed, and your power supply is above 9VDC, contact your vendor and request replacements.

Now that you have determined your TX-01 and RE-01 boards are functioning accurately, the transmitter and receiver can be tested. Attach the transmitter to the encoder board and apply power. Attach the receiver to the decoder board, position them about 50 feet away from the encoder/transmitter boards, and apply power. If the address of the encoder matches the address of the decoder, and the power supply is at least 9VDC for both the TX-01 and RE-01, the Valid ID relay on the RE-01 should be closed. If the relay is not closed, an attempt should be made to tune the receiver board.

The frequency of the receiver board can be modified by carefully turning the variable capacitor located on top of the receiver board. This should be done with a plastic or ceramic screw-driver. The variable capacitor looks a lot like a flat head screw and has a half-turn range. This means that if you have adjusted the capacitor more than one half of a turn in either direction, you will have gone through the entire range of the capacitor and should have picked up the signal. Continue slowly turning the capacitor until the Valid ID relay closes. This procedure can be repeated at various distances up to 100 feet away from the transmitter. The guaranteed operating distance of these sets is 50 feet, but with a little attention and a wire antenna these boards are capable of about 100 feet. If you are unable to achieve the guaranteed distance of 50 feet, or if you feel that tuning these boards is beyond your ability, please contact your vendor for replacements. These boards are tuned from the factory and should have at least a 50 foot range. Tuning is only recommended when greater distances are required or in the event that a board appears to be defective.

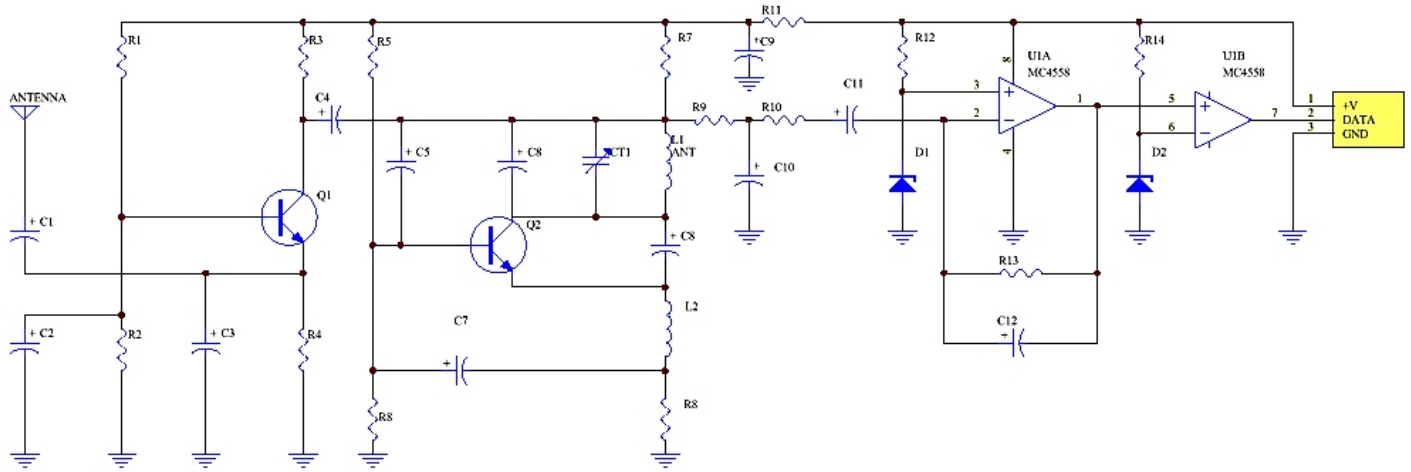

GENERAL INFORMATION THAT APPLIES TO OUR REMOTE CONTROL PRODUCTS

BREAKDOWN OF A REMOTE CONTROL SYSTEM:

A remote control system is any system with controls or commands delivered to the main unit from a distance, in this case by way of radio frequency transmission. The remote system we will discuss includes an encoder, transmitter, receiver, and decoder. All of these parts must be used in order to attain a complete link. See descriptions below.

ENCODER:

An encoder is a circuit in which a code or signal presented in one format can be changed to a format compatible with the circuitry it interfaces with. In the case of the TX-01 the format delivered by the user is a 12-bit parallel code consisting of 8 address bits and 4 data bits. This code must be changed to a serial format in order to become compatible with the transmitters input. This is the job of the TX-01 encoder motherboard, or more specifically, the HT12E encoder IC found on the TX-01 encoder motherboard.

TRANSMITTER:

A transmitter is a circuit with an output sent through the air by light, sound or electromagnetic waves at a specific frequency. In the case of the TX-99, the output is an amplitude modulated radio frequency of 300MHz. The transmitter receives a coded signal from the encoder and uses that signal to modulate its 300MHz carrier. In simple terms, the output of the transmitter is an electromagnetic representation of the input data code.

RECEIVER:

A receiver is a circuit capable of accepting and processing light, sound, or electromagnetic waves of a specific frequency. In the case of the RE-99, the 300MHz radio frequency signal sent by the transmitter is received, and the incoming data extracted from that signal. The extracted data is then sent out in serial format to the decoder board.

DECODER:

A decoder is a circuit in which a coded signal of a specific format (usually that of its compatible encoder) is received and changed to a format compatible with the circuitry it interfaces with (usually the format originally presented to the encoder is the same format used for the output of the decoder when used in wireless systems, but not always). In the case of the RE-01, the incoming code is a 12-bit serial format. This code must be checked to ensure that the first 8 bits (address bits) match the address of the decoder IC. This is the job of the RE-01 decoder motherboard, or more specifically, the HT12D decoder IC found on the RE-01 decoder motherboard. If the incoming 8-bit address is correct, the last 4 bits of the 12-bit code (data bits) are passed on to the data outputs of the RE-01, and the Valid ID relay closes and remains closed until the incoming signal is no longer present. The 4 data bits, however, latch and remain in whatever state they were set to by the last transmission, until they are changed by the next transmission.

DATA CODES:

A data code is a set of numbers or letters representing some form of information. In the case of the encoders and decoders described above, the data code consists of a combination of four 1s and/or 0s representing 16 possible states. If a +5V signal is applied to one of the four data lines, or if the data line is left floating (not connected), this is considered a 1. If +0V (or ground) is applied to one of the four data lines, this is considered a 0. By using different combinations of 1s and 0s on the four data lines, 16 separate control commands can be sent. IC's are available, such as the 74HC154, which can turn the 4 bit data output of the RE-01 into a more user friendly output, giving you the option to select 1 of 16 different output pins to activate per transmission. If the 4-bit data code is being sent to a micro-controller, or if less than 4 different commands are needed, these extra IC's are not needed.

IMPORTANT NOTE:

The bandwidth utilized on our RF modules was intended for experimental use in applications that require only short burst transmissions. Our RF boards must be used with their intended motherboards (TX-01 & RE-01) and cannot be used for continuous serial data applications.

Ming Microsystem's RF products are designed for experimental use and are not FCC approved. It is the responsibility of the user to verify compliance with FCC regulations on their own application and obtain an FCC approval number for the final product which is to be marketed.

LIMITED WARRANTY

This product is warranted against manufacturing defects in materials and workmanship for 30-days from the date of purchase. Within this period, Ming Microsystem will, at its option, repair or replace the product, or any part thereof, without charge for parts and labor.

This warranty does not apply in the following cases: Improper installation, misuse, failure to follow installation and operating instructions, alteration, abuse, accident or tampering.

Ming Microsystem is not responsible or liable for indirect, special, or consequential damages arising out of or in connection with the use or performance of the product or other damage with respect to any economic loss, loss of property, loss of revenues or profit, or costs of removal, installation or reinstallation.

Except as provided herein, Ming Microsystem makes no express warranties, and any implied warrant of merchantability or fitness for particular purpose is limited in its duration to the duration of the written limited warranties set forth herein.

There will be charges rendered repairs to the product made after the expiration of the aforesaid 30-days warranty period.

This warranty gives you specific legal rights and you may have other rights which vary from state to state.

**FOR TECHNICAL SUPPORT
PLEASE CALL (626) 961-6273**

**www.ming-micro.com
support@ming-micro.com**