

# Fire-Stick II

<http://www.rentron.com>



Wireless infrared communications links are quick, easy, and affordable with Fire-Stick II. Microcontrollers like the BASIC Stamp, PIC, and 8051 can transmit serial data by infrared with a single I/O-pin. The receiver circuit requires only an infrared detector module such as the Panasonic PNA4602M for serial data reception at baud rates up to 2400.

## Sample Code For Receiving Serial Data:

```
baud   con    813    '1200 Baud, (NON-INVERTED)

start:
  serin 0,baud,[wait("A"),b0]  ' Wait for ASCII letter A
  debug ? b0                    ' Show value received
  debug cr                       ' Carriage return
  goto start
```

## Sample Code For Sending Serial Data:

```
time   var    byte
time   =      250
baud   con    17197 '1200 Baud, (INVERTED)
number var    byte

begin:
  for number = 1 to 100
    serout 15,baud,["A",number] ' N1200 baud
    pause time
  next
  goto begin
```

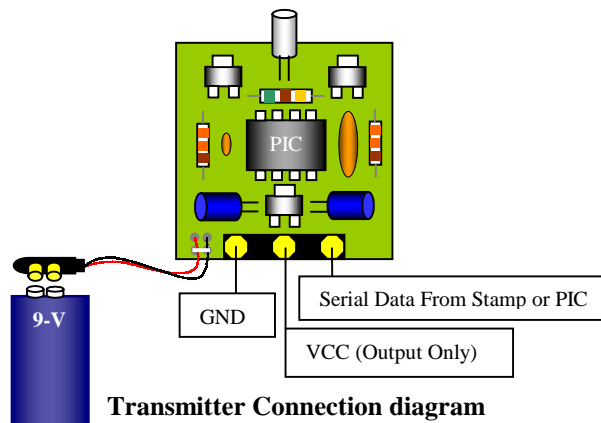

**Transmitter Connection diagram**

# *Fire-Stick II*

<http://www.rentron.com>

**Note:** The Fire-Stick II onboard +5V regulator provides a regulated +5 VDC for all components with the exception of the infrared LED. Power for the LED is taken directly from the unregulated battery input to the regulator. This must not exceed +9 VDC.

No connections should be made to the Fire-Stick II Vcc header-pin unless the onboard regulator is providing power for both circuits. If you use Fire-Stick II to power the Stamp or other controller circuit, connect the Fire-Stick II Vcc output-pin to the controller circuit Vcc.

## **The Receiver Circuit:**

Receiving data from Fire-Stick II is quick & painless. The only component necessary to receive data is a single infrared detector module. With the lens of the (PNA4602M) Panasonic infrared detector facing you – the left pin is the data output pin. Connect this pin directly to any free I/O-pin you have available on the receiving Stamp, PIC or other microcontroller.

The center pin connects to power supply ground. The remaining pin on the right side connects to +5 volts DC. Do not exceed 5 volts supply for the detector module circuit.

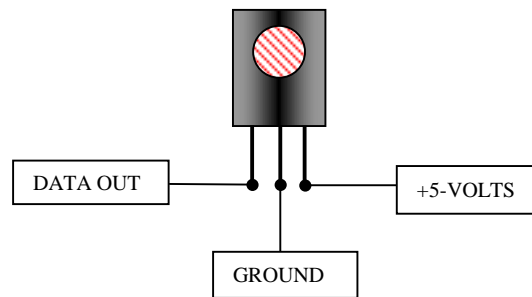

## **Power Supply:**

Fire-Stick II is designed to be powered by a standard 9-volt battery, but will work with any DC power supply from 7.5 to 9 volts DC. A minimum of 7.5 volts DC must be maintained on the un-regulated power input to the onboard LM340 regulator in order to maintain a regulated +5 volts DC output.

Stay below 500mA total current when using the onboard regulator to supply power to your controller circuit. There is no heat sink on the circuit board to absorb excess heat at higher current demands, and staying within 500mA will increase the life of the LM340 regulator, and avoid excessive heat. Fire-Stick II can easily supply power to your BASIC Stamp or PIC circuitry, but stay within the 500mA range.

- Carrier frequency: 38.5KHz (40KHz available on request)
- Maximum operating range @ 9 VDC: 40-60 foot (indoors).
- Average current (continuous transmit): 30mA.
- Average current (idle): 6mA.
- Peak pulse current: 1A @ 9 VDC.
- Infrared LED beam angle: 60 degrees.
- Infrared LED wavelength: 940nm.

For more information on using Fire-Stick II, and complete projects, please visit our web site at <http://www.rentron.com/FS-2.htm>

## Fire-Stick II Assembly Instructions

<http://www.rentron.com>

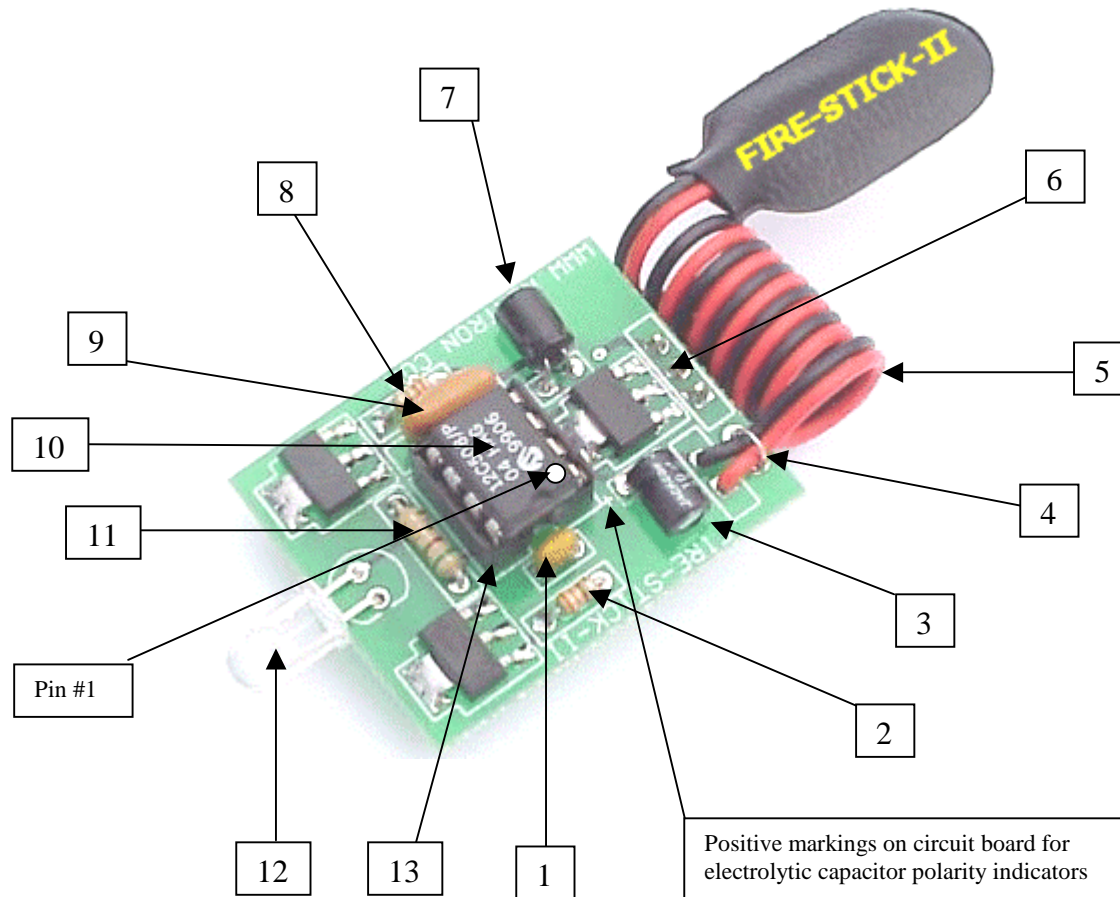

### Parts List:

1. 0.01uF 50V ceramic capacitor [ marked 103, non-polarized capacitor ]
2. 1/8W 300 ohm resistor [ orange, orange, brown ]
3. 10uF 25V electrolytic capacitor
4. Resistor lead wire used as strain relief for battery cable
5. 9-volt battery cable
6. 3-pin 0.1 header
7. 1uF 50V electrolytic capacitor
8. 1/8W 330 ohm resistor [ orange, orange, brown ]
9. 4MHz ceramic resonator
10. PIC12C508 microcontroller
11. 1/4W 5.1 ohm resistor [ green, brown, gold ]
12. 940 nm Infrared LED [ OED-EL-1L2 ]
13. 8-pin IC DIP socket for microcontroller

### Notes:

1. Part #4 is a resistor lead wire trimmed off for use as a battery cable strain relief.
2. Parts #3 & #7 are **polarized** electrolytic capacitors. Negative terminals of these capacitors are marked with a large white ( - ) symbol. The side with the white ( - ) mark faces **away** from the positive mark ( + ) symbol on circuit board.
3. For part #12 (IR LED) be sure LED cathode side (flat side of LED) matches flat mark on circuit board.
4. Observe pin #1 orientation when inserting part #10 PIC12C508 into the 8-pin IC socket. (pin #1 is marked with a white dot on above photo)