

Features

- Compact package
- High immunity from ambient light
- Good performance against electric field disturbance
- 5 volt supply voltage and low power consumption
- Pin out can be changed according to customer's requirement

Description

The LTM-97 series are miniaturized receivers for infrared remote control systems. It is a single unit type module which incorporates a PIN diode and a receiving preamplifier IC. The demodulated output signal can directly be decoded by a microprocessor. It has excellent sensitivity and reliable function even in disturbed working environment.

Device No.

Device No.	Detecting Window	Package Dimension	Pin Out Function		
			3	2	1
LTM-97AS-XX	Side	A	Gnd	Vcc	Vout
LTM-97AT-XX	Top	B			
LTM-97BS-XX	Side	C	Gnd	Vcc	Vout
LTM-97BT-XX	Top	D			
LTM-97CS-XX	Side	C	Vcc	Vout	Gnd
LTM-97CT-XX	Top	D			
LTM-97DS-XX	Side	C	Vout	Vcc	Gnd
LTM-97DT-XX	Top	D			
LTM-97ES-XX	Side	C	Vout	Gnd	Vcc
LTM-97ET-XX	Top	D			

XX: Carrier frequencies for 33, 36, 38, 40, 56.8 kHz

Package Dimensions

A. LTM-97AS-XX

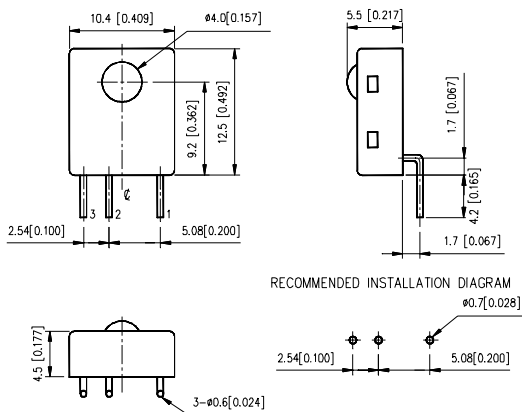

B. LTM-97AT-XX

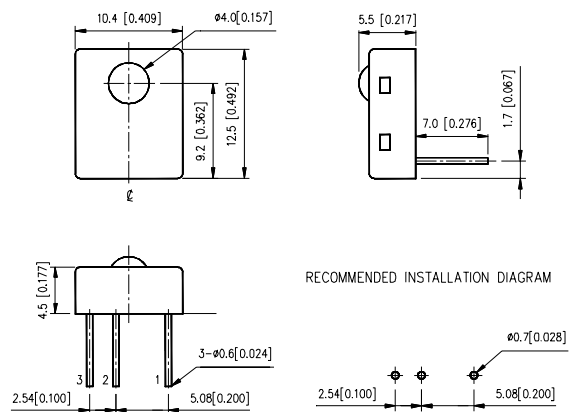

C. LTM-97BS/CS/DS/ES-XX

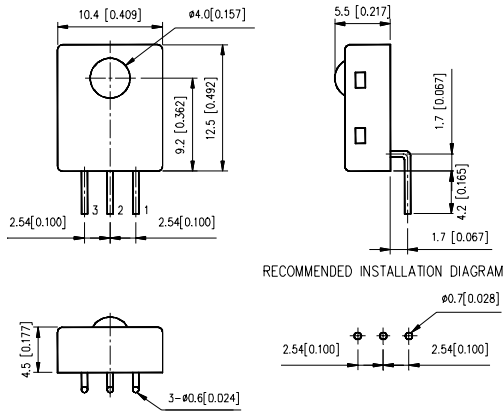

D. LTM-97BT/CT/DT/ET-XX

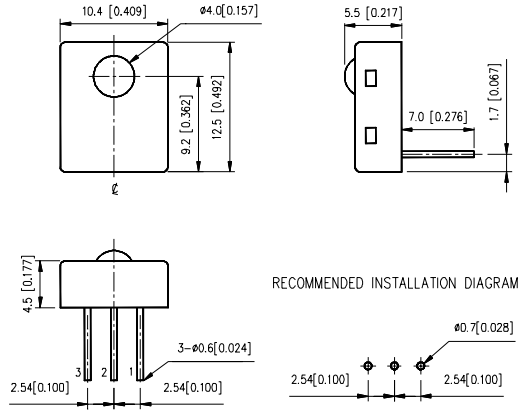

Note: 1. All dimensions are in millimeters (inches).
 2. Tolerance is $\pm 0.25\text{mm}$ (0.01") unless otherwise noted.
 3. XX: Frequency

Special Forming (Option)

- We provide lead forming service if it's necessary.
- "*" Dimension can be changed according to customer's requirement

A. LTM-97AS-XX#

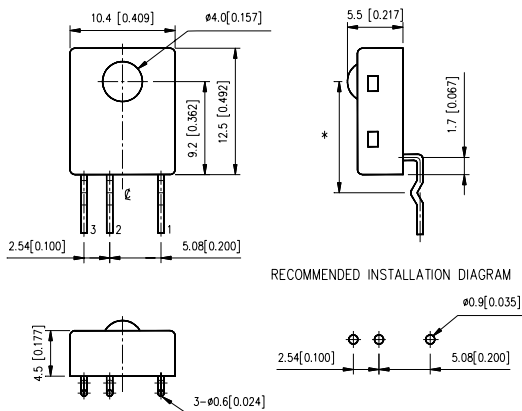

B. LTM-97AT-XX#

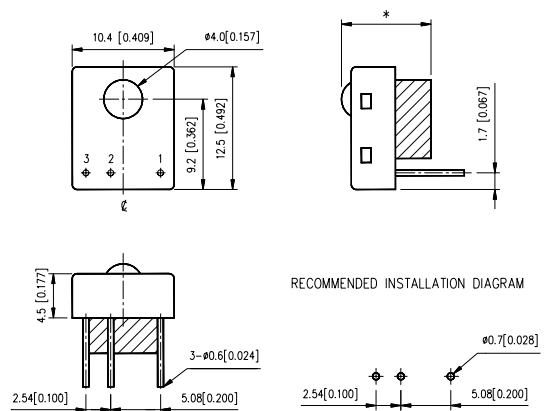

Block Diagram

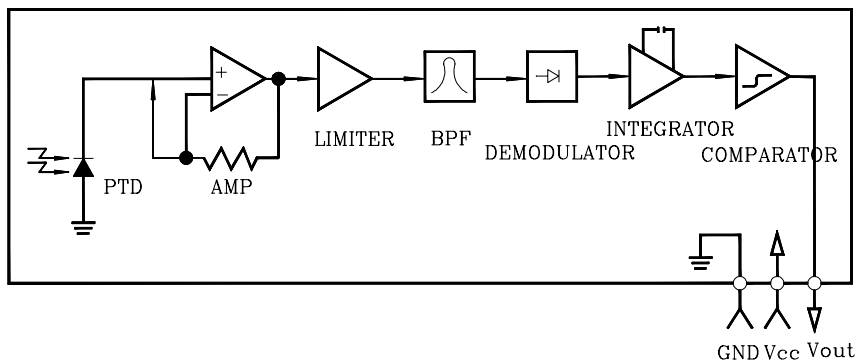

Application Circuit

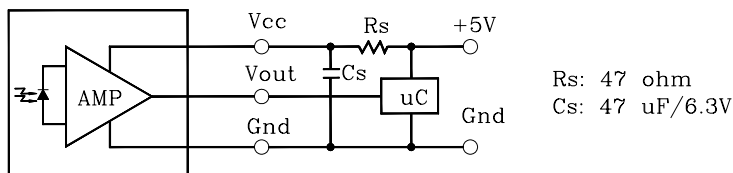

- Rs and Cs is only necessary to suppress power supply disturbance.

Electrical Characteristics

Item	Symbol	Conditions	Rating			Unit
			Min	Typ	Max	
Current Consumption	I _{cc}	No signal input, V _{cc} =5V	1.1		2.5	mA
Wave Length of the Max. Sensitivity	λ S _{max}	—		940		nm
Reception Distance	L	At the ray axis	10			m
		The ray receiving surface at a vertex and in relation to the ray axis: a: in the range of 30° cone b: in the range of 45° cone	8 6			
Low Level Output Voltage	V _{OL}	—			0.5	V
High Level Output Voltage	V _{OH}	—	4.5			V
Low Level Pulse Width	t _{WL}	Specified by the output tWL period within a range from 5cm to the reception distance	400	600	800	μS
High Level Pulse Width	t _{WH}	Specified by the output tWH period within a range from 5cm to the reception distance	400	600	800	μS
Noise Suppression	NQ	25-50°C No outside light			0	Pulse

Note: Detailed condition please refer to measuring method.

Measuring Method

A. Reception distance measurement

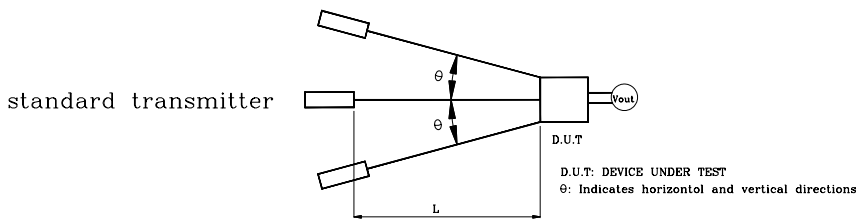

Fig. 1 Reception distance measuring condition

B. Standard transmitter

The transmitter whose output is adjusted up become $V_o=400m$ Vp-p by output waveform as show in Fig. 2 and the measuring method as shown in Fig. 3 is specified as the standard transmitter. However, the infrared diode to be used for the transmitter should be $\lambda_p=940nm$, $\Delta\lambda=50nm$.

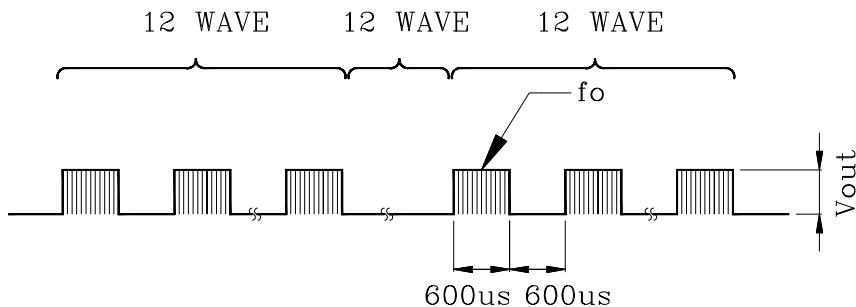

Fig. 2 Output wave form

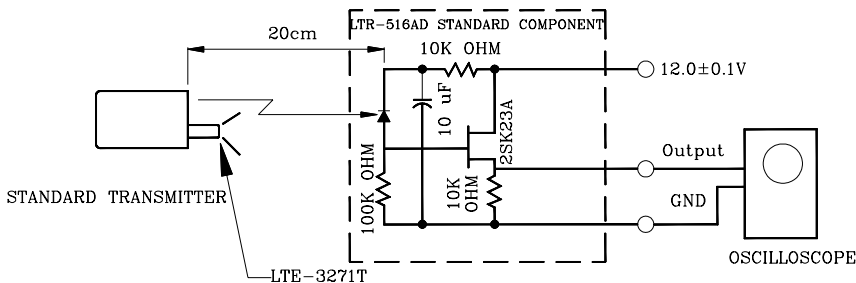

Fig. 3 Measuring method

C. Pulse width measurement

The following wave forms are transmitter output and our receiver module's output.

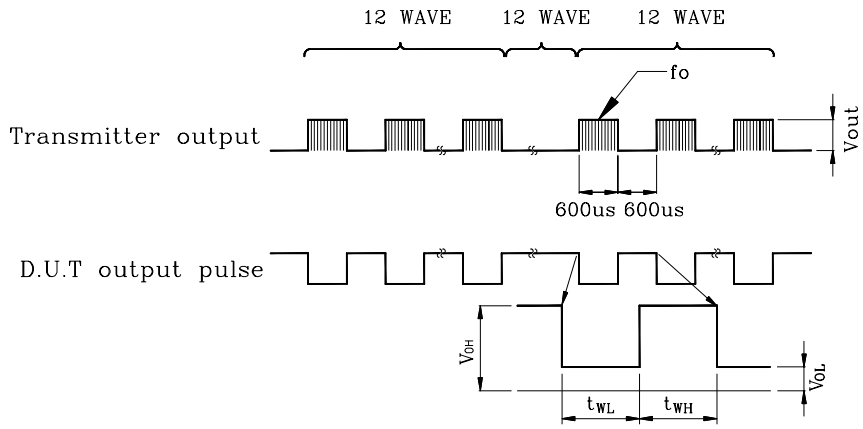

Fig. 4 Output pulse