

IR-DX8

8-Bit Infrared Remote Control Encoder / Decoder IC

The IR-DX8 is a custom infrared encoder/decoder IC designed by Reynolds Electronics for infrared remote control applications requiring flexibility & unique features not available with other remote control encoder or decoder ICs. The IR-DX8 is truly a single-chip remote control solution.

The IR-DX8 combines the functionality of both encoder and decoder in a single package with several unique features for enhanced operation and a reduced component count for infrared transmitter and receiver circuits.

The MODE pin configures the IR-DX8 IC for encode or decode operation. The L/M pin selects latching (L) or momentary (/M) outputs when the IR-DX8 is configured for decode mode.

Note: The MODE input must be wired directly to Vdd or circuit ground *before* power is applied. The IR-DX8 IC will configure itself automatically for encode or decode operation based on the logic state of the MODE input at power-up.

Latching or Momentary Outputs

The logic applied to the L/M pin selects latching or momentary output modes only when the IR-DX8 is configured for decode mode.

Decode Mode / Latching Outputs:

MODE = Vdd (Decode Function Selected)
L/M = Vdd (Latching Outputs Selected)
R/T = Receives IR Signal From Detector
A0-A4 = 5-Bit Address Inputs
D0-D7 = 8-Bit Latching Outputs

Decode Mode / Momentary Outputs:

MODE = Vdd (Decode Function Selected)
L/M = Ground (Momentary Outputs Selected)
R/T = Receives IR Signal From Detector
A0-A4 = 5-Bit Address Inputs
D0-D7 = 8-Bit Momentary Outputs

Decoder outputs can sink or source up to 25mA per pin with a total combined device package MAX of 200mA allowing direct remote control of LED's, solid-state relays, and other logic devices without the need for secondary driver circuits.

See the IR-DX8 example application schematics for encoder & decoder circuit configurations.

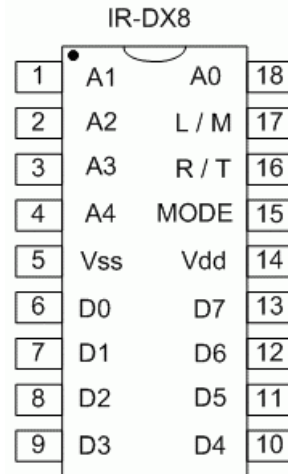

Encode Mode:

MODE = Ground (Encode Function Selected)
L/M = Ground or Vdd (Used Only by Decoder)
R/T = Transmit Output For IR LED
A0-A4 = 5-Bit Address Inputs
D0-D7 = 8-Bit Data Input (Button Inputs)

The L/M pin is sampled only when the IR-DX8 is in decode mode. In encode mode this pin must be connected to Vdd or ground, and should not be allowed to float.

When configured for encode mode, connecting any of the data inputs D0-D7 to ground will initiate a continuous infrared transmission at 40kHz. Removing ground from a data input will end the transmission.

Latching Key-Press

With the decoder in latch mode, data inputs D0-D7 of the encoder must be pressed & released one at a time to toggle decoder outputs on or off individually. Multiple key presses are not allowed on the encoder when the decoder is configured for latch mode.

Momentary Key-Press

In momentary mode, any combination of the encoder data inputs D0-D7 may be grounded simultaneously.

IR-DX8

8-Bit **Infrared** Remote Control Encoder / Decoder IC

Data & Address Validation

Encoder address pins A0-A4 must be set to the same logic levels as decoder address pins A0-A4. If these do not match, the decoder will ignore data sent from the encoder. The decoder must receive two consecutive & matching data/address packets before transferring data to the D0-D7 outputs. Each 13-bit packet transmit time requires approximately 48mS. Care should be taken not to violate these timing requirements when the IR-DX8 is controlled by high-speed logic circuits or embedded controllers such as the PIC, BASIC Stamp or 8051.

Important: Address input pins A0-A4, L/M, and the MODE input must **always** be connected to Vdd or circuit ground depending on the mode required. Allowing any of these input pins to "float" (leaving them un-connected) will cause erratic results.

Maximum Input/Output Sink/Source Current On Any Pin..... 25mA
Maximum Input/Output Sink/Source Current Total 200mA
Operating Voltage 3.0-5.0VDC well filtered
Avg. No Load Operating Current <2mA @5.0VDC
Carrier Frequency / Duty Cycle +/- 2%. 40kHz / 50%

DISCLAIMER

Reynolds Electronics reserves the right to make changes without notice. The information contained in this document is believed to be accurate at the time of publication. Specifications are based on lot samples. Values may vary from lot to lot, and are not guaranteed. Reynolds Electronics makes no guarantee, warranty, or representation regarding the suitability or legality of any product for use in a specific application. None of these devices are intended for use in applications of a critical nature where safety, life, or property is at risk. The user of this product assumes full liability for the use of this product in all applications. Under no conditions will Reynolds Electronics be responsible for losses arising from the use or failure of the device in any application, other than the repair, replacement, or refund limited to the original product purchase price.

Technical support:
Email: support@rentron.com
Sales: sales@rentron.com
Distributor inquiries: sales@rentron.com

Copyright © 2007 Reynolds Electronics
Web Site: <http://www.rentron.com>

The IR-DX8 are available for purchase online at: <http://www.rentron.com/IR-DX8.htm>

IR-DX8

THE SINGLE IC SOLUTION FOR BOTH REMOTE CONTROL, TRANSMITTER AND RECEIVER
 USER SELECTABLE MOMENTARY OR LATCHING OUTPUTS
 8-BITS DATA WITH UP TO 25mA PER OUTPUT
 5-BIT ADDRESS

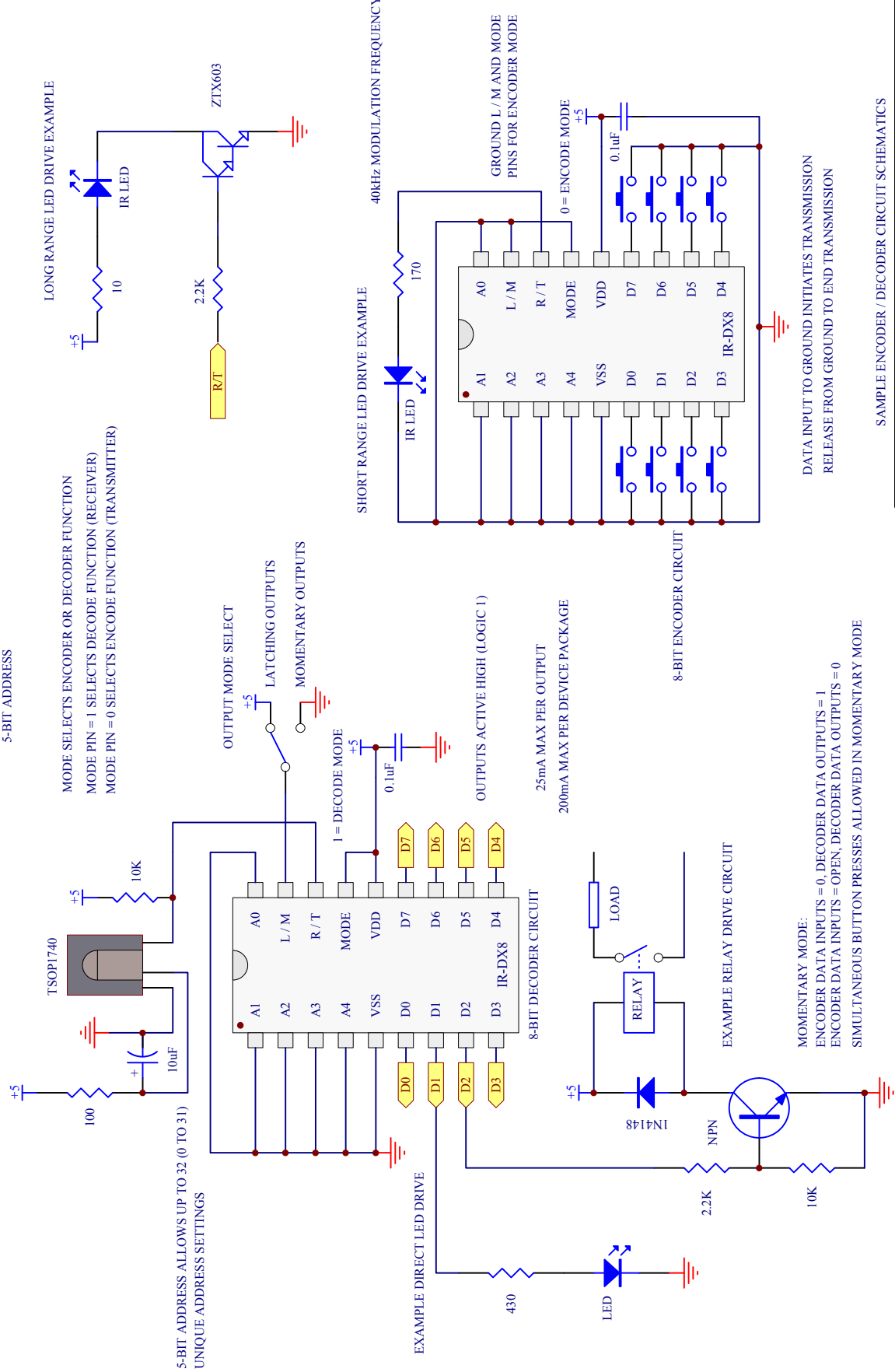

MODE SELECTS ENCODER OR DECODER FUNCTION
 MODE PIN = 1 SELECTS DECODE FUNCTION (RECEIVER)
 MODE PIN = 0 SELECTS ENCODE FUNCTION (TRANSMITTER)

OUTPUT MODE SELECT
 LATCHING OUTPUTS
 MOMENTARY OUTPUTS

5-BIT ADDRESS ALLOWS UP TO 32 (0 TO 31) UNIQUE ADDRESS SETTINGS

8-BIT DECODER CIRCUIT
 25mA MAX PER OUTPUT
 200mA MAX PER DEVICE PACKAGE

EXAMPLE RELAY DRIVE CIRCUIT

MOMENTARY MODE:
 ENCODER DATA INPUTS = 0, DECODER DATA OUTPUTS = 1
 ENCODER DATA INPUTS = OPEN, DECODER DATA OUTPUTS = 0
 SIMULTANEOUS BUTTON PRESSES ALLOWED IN MOMENTARY MODE

LATCHING MODE:
 PRESS & RELEASE "SINGLE" ENCODER INPUT BUTTON, DECODER OUTPUT = 1
 PRESS & RELEASE SAME "SINGLE" ENCODER INPUT BUTTON, DECODER OUTPUT = 0
 ONLY SINGLE BUTTON PRESSES ALLOWED IN LATCH MODE
 USER MUST PRESS & RELEASE BUTTONS INDIVIDUALLY
 TO TOGGLE THE LOGIC STATE OF DECODER OUTPUTS

DATA INPUT TO GROUND INITIATES TRANSMISSION
 RELEASE FROM GROUND TO END TRANSMISSION

SAMPLE ENCODER / DECODER CIRCUIT SCHEMATICS

Title		IR-DX8 40kHz INFRARED ENCODER / DECODER IC	A.1
Size	Number	Revision	B. REYNOLDS
OrCAD A			
Date:	14-Mar-2004		
File:	C:\CAD\SCHEMATICS\Ddb		
	Sheet of	4	
	Drawn By:		