

### **Description**

The CIP-8 series 8-bit encoder/decoder IC's offer an easy to use, low-cost solution for simple remote control applications in a convenient industry standard 20-pin PDIP package.

### **Encoder Operation**

On power-up the encoder enters low power sleep mode. When the transmit enable pin is pulled to ground, the encoder will wake up and begin the transmit process.

First, the encoder will record the state of the 8-bit address/data lines, encode for error correction and assemble the packet.

It will then sample the A0/BAUD pin to fix the data rate, and then output the address and encoded data packet on DOUT.

The encode/transmit process will continue for as long as the /TE pin is low, and return to low power sleep mode when /TE returns high.

It will update the state of the address and data lines with each packet and finish the current transmission even after the /TE pin is released from ground.

### **Encoded Data Packet**

Each data packet consists of seven bytes of information to be transmitted.

- The preamble
- The synchronization byte
- The 1<sup>st</sup> address byte
- The 1<sup>st</sup> data byte
- The 2<sup>nd</sup> address byte
- The 2<sup>nd</sup> data byte
- The address/data checksum

A 10mS guard time is inserted between each encoded packet transmission to allow the decoder time to receive, decode, verify, and process each packet. The encoder returns to low power sleep mode for power conservation immediately once /TE returns to logic 1, and the packet transmission is complete.

### **Features**

- Latched or momentary outputs
- No programming necessary
- Very easy to use
- Very low component count
- Low current consumption
- Up to 25mA per decoder output
- Eight bit data (D0 to D7)
- Eight bit binary address (0 to 255)
- Selectable baud rates (2400/4800)
- High noise immunity
- Standard 20-pin PDIP package

### **Applications**

- Simple remote control
- Wire elimination
- Remote status monitoring
- Remote lighting control

### **Decoder Operation**

The decoder enters a timed loop waiting for the synchronization byte. An internal 16-bit timer is used to force an exit from the receive loop, and reset the output pins (in momentary mode) every 65.5mS if no valid synch byte is received during this time period.

Once a valid synch byte is received, the timer is disabled, and the remainder of the data packet is received and stored for the verification process.

Immediately after receiving a valid data packet it begins the process of verifying the data, and checking it for errors.

Once data has been verified, the decoded data will be placed on the output pins, and the decoder re-enters the timed loop waiting for the next valid packet.

If the decoder is operating in latch mode, the last valid 8-bit binary data value received will remain on the decoder outputs until a different valid binary data packet is received.

### **Pin Descriptions**

Pins A0 to A7 on the CIP-8 encoder and decoder IC's are used to set a unique address relationship between the encoder and decoder.

This helps prevent accidental activation of decoder outputs, and allows a single encoder the ability to control multiple decoders by simply changing the encoder address to match the decoder to control.

Ensure the address set on the encoder matches the decoder you wish to control. A single bit difference, and the decoder will not respond.

### **A0/BAUD Pin**

The A0/BAUD input serves two functions. One is being the least significant bit of the 8-bit encoder/decoder address. Two is being the data rate selection pin. With A0/BAUD connected to ground, the least significant bit of the 8-bit binary address is 0, and the serial data rate is 2400bps.

With this pin at Vcc, the least significant address bit is 1, and the serial data rate is 4800bps. This option allows support for low-end RF modules that require the lower data rates, while providing the faster data rate option for higher end RF modules such as the excellent Linx Technologies® LR series, and others.

### **Encoder & Decoder Data Pins D0-D7**

On the encoder, pins D0-D7 are the data input pins. The logic value present on these inputs will be transferred to the corresponding D0-D7 data output pins on the decoder when /TE (transmit enable) pin on the encoder is pulled to ground.

### **Encoder /TE Pin**

/TE is the transmit enable pin. This pin will cause the encoder to sample the address and data pins, and transmit continuously while held at ground. Returning /TE to Vcc through the pull-up resistor as shown in the CIP-8 example schematics will end the transmission, and place the encoder in low power sleep mode.

### **Decoder Latch/Momentary Modes**

The decoder L/M pin provides a mode select to switch between momentary or latched decoder operating modes.

Logic 1 = Latch Mode

Logic 0 = Momentary Mode

In momentary mode, the decoder outputs that will maintain the 8-bit data value being received for the duration of valid address and data reception.

If any part of the verification process fails, or reception is interrupted for longer than 65.5mS, decoder will timeout, immediately discard the packet, reset the timer, force all decoder data outputs back to ground, and re-enter the timed loop waiting for the next packet.

When receiving a continuous stream of valid data, the timer is disabled, and the decoder will respond rapidly to changing data values, and hold the received binary pattern on the outputs.

### **Connect All Pins**

All address, data, and function select pins such as /TE, and L/M pins must be connected to either Vcc or ground as required. Leaving any pins floating (not connected) will cause erratic operation of the encoder, decoder, or both.

Ensure that encoder data inputs D0-D7 are at the required logic levels before the /TE pin is pulled to ground.

When prototyping circuits on a breadboard, it may be desirable to test logic levels on all encoder/decoder pins with a logic probe or meter before operation.

### **VCC And Ground**

VCC is the positive power supply. GND is ground.

<b>Ordering Information</b>	
Part #	Description
CIP-8D	8-Bit Decoder IC
CIP-8E	8-Bit Encoder IC



# CIP-8E / CIP-8D 8-BIT ENCODER / DECODER EXAMPLES

NOTE: ALL ADDRESS PINS MUST BE AT GROUND OR VCC  
DO NOT ALLOW TO FLOAT

THE SINGLE IC SOLUTION FOR BOTH REMOTE CONTROL TRANSMITTER AND RECEIVER  
8-BITS ADDRESS / DATA WITH UP TO 25mA PER DECODER OUTPUT

VCC = +3.0V TO +5.5V DC  
WITH < 20mV P-P NOISE / HASH FOR BEST RESULTS

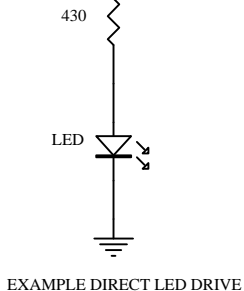
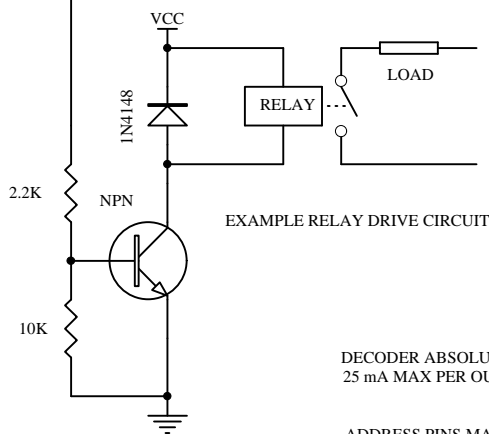
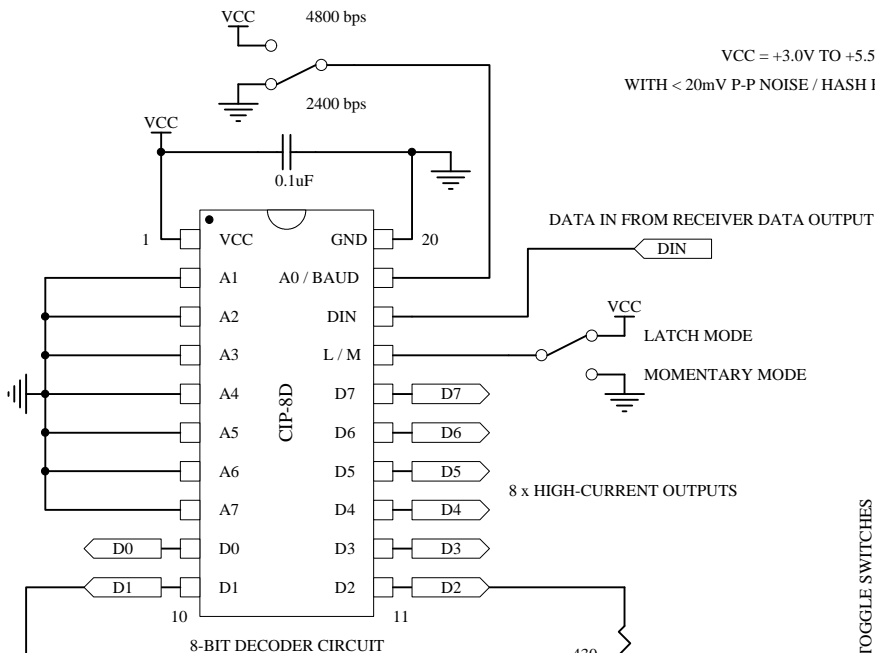

DECODER ABSOLUTE MAX DRIVE CURRENT:  
25 mA MAX PER OUTPUT PIN | SINK OR SOURCE | 200 mA MAX (ALL COMBINED)

ADDRESS PINS MAY BE CONNECTED TO GROUND, VCC, OR ANY COMBINATION  
OF GROUND & VCC, AND SHOULD NOT BE ALLOWED TO FLOAT

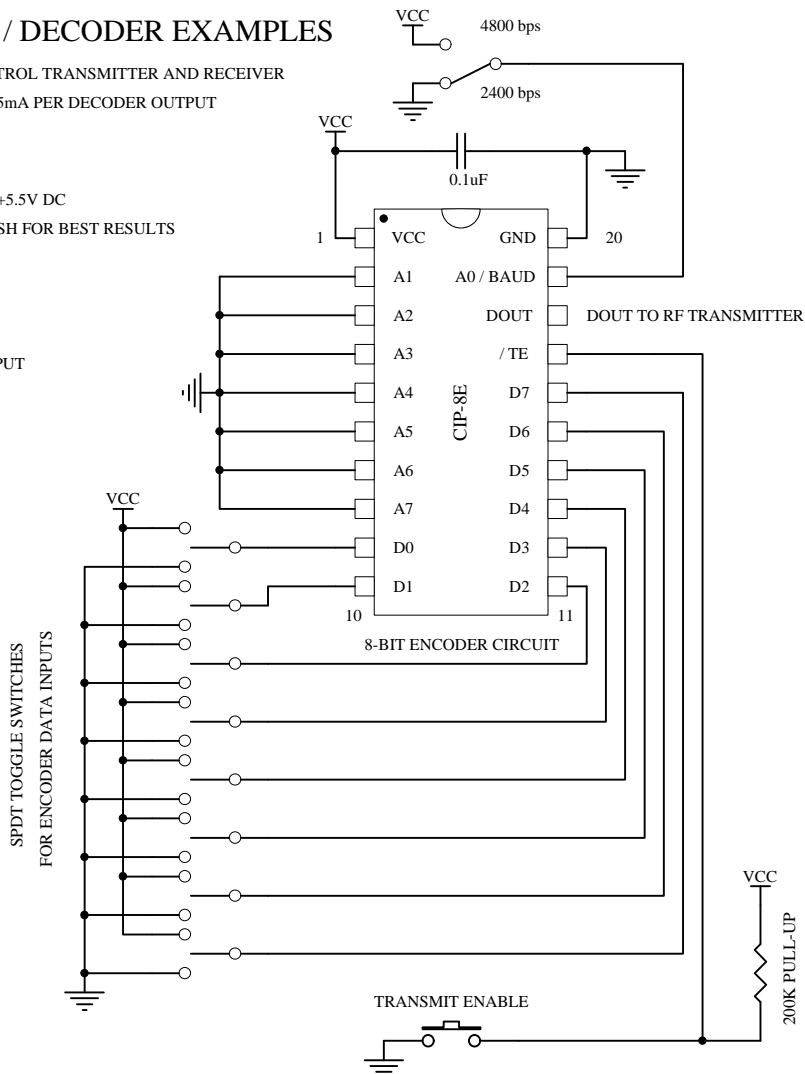

GROUNDING /TE PIN INITIATES DATA TRANSMISSION  
USE 100K TO 200K EXTERNAL PULL-UP AS SHOWN ABOVE

Title			SAMPLE ENCODER / DECODER CIRCUIT SCHEMATICS FOR 8-BIT "CIP-8E" ENCODER & "CIP-8D" DECODER IC's		
Size	Number	Revision		A.1	
Orcad A	CIP-8E / CIP-8D				
Date:	7-Nov-2006	Sheet of	1 of 1		
File:	C:\CAD\SCHEMATICS.Ddb	Drawn By:	B. REYNOLDS		